

D.C.E.M DBM BRAKE - 500 MM



INTRODUCTION

SOC make Electromagnetic brakes are used in conjunction with other equipments where smooth, rapid and dependable stopping is required. Electromagnetic DBM brakes are electrically released & spring set. When the coil is energized the armature are attracted together to compress the torque spring and move the shoes away from the wheel, thus releasing the brake.

De-energizing the coil allows the torque spring to separate the armatures and press the shoes against the wheel setting the brakes thus making it fail safe in the event of power failure.

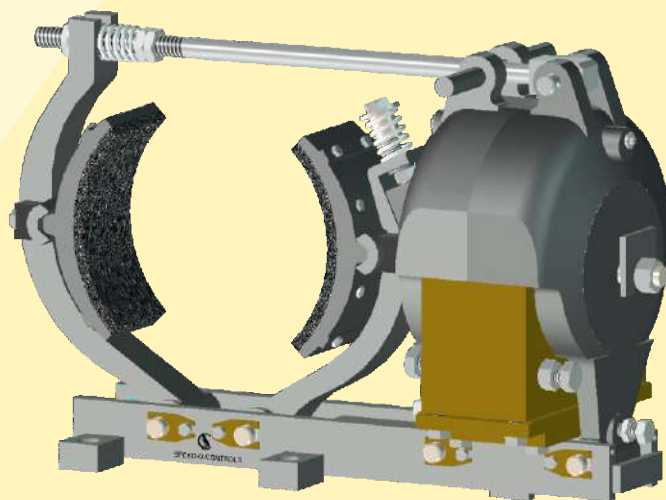

TECHNICAL DATA

MODEL	DBM - 500
ITEM CODE	900900091001
DRUM DIA (MM)	500
BRAKING TORQUE (Kgm)	277 (INTERMITTENT) 207.8 (CONTINUOUS)
STROKE	3
VOLTAGE INPUT (AC)	415V THROUGH RECTIFIER
VOLTAGE INPUT (DC)	370 VDC (INRUSH)
	89.6 VDC (HOLDING)
OPERATING TEMPERATURE	-30°C TO +50°C
COIL	COPPER WIRE EPOXY RESIN ENCAPSULATED
RATING	INTERMITTENT/CONTINUOUS
NO OF OPERATIONS (MAX)	720/Hr
INSULATION	H CLASS
WEIGHT	600 Kg

SELECTION OF BRAKE SIZE

The brake torque must be \Rightarrow than motor full load as referred with drum. Formula as below:

$$T = \text{Torque in Kgm} = \frac{716 \times \text{Hp}}{\text{rpm}}$$

$$T = \text{Torque in Nm} = \frac{9552 \times \text{Kw}}{\text{rpm}}$$

Where Hp/Kw = motor output & rpm = Rev/minute

