

Introduction

Worm Drive Limit Switches are suitable for use on reversing drives, such as Hoists, Cranes, Winches, Rolling Mills, Theaters, Coke Ovens etc. The driving motion is transmitted by worm gear. All gears and hubs are made of low wear thermoplastic. The rotational movements are transmitted to switches by adjustable cams.

Technical Data :

Body Material	Black GFN
Cover Material	Yellow
Protection Degree	Impact-proof Thermo-Plastic
Operating Temperature	IP-55 (IS/IEC:60529(2001)
Mounting Position	- 25°C to 70°C
Gear Ratios	Any position mounting
Drive	1:12.5, 1:25, 1:50, 1:100, 1:200 and 1:400
Cable Entries	Worm Screw
Input Speed	Twin, 3/4 " BS Conduit
Contact Material	1200 RPM, Maximum
Wire Connection	Double brake, Silver Cadmium(snap)
Rated voltage	Screw terminal contact
Thermal Test Current	up to 600 V AC
No. Of Contacts	10 A
Mechanical / Electrical Life	2 NC OR 4 NC
	1 Million Operations



Code	Ratios	Useful Rotations	2 Contacts Model 2 NC	4 Contacts Model 4 NC
101100010001	1 : 12.5	11.6	FG - 12.5 P2	FG - 12.5 P4
101100020001	1 : 25	23.2	FG - 25 P2	FG - 25 P4
101100030001	1 : 50	46.5	FG - 50 P2	FG - 50 P4
101100040001	1 : 100	93	FG - 100 P2	FG - 100 P4
101100050001	1 : 200	185	FG - 200 P2	FG - 200 P4
101100060001	1 : 400	372	FG - 400 P2	FG - 400 P4

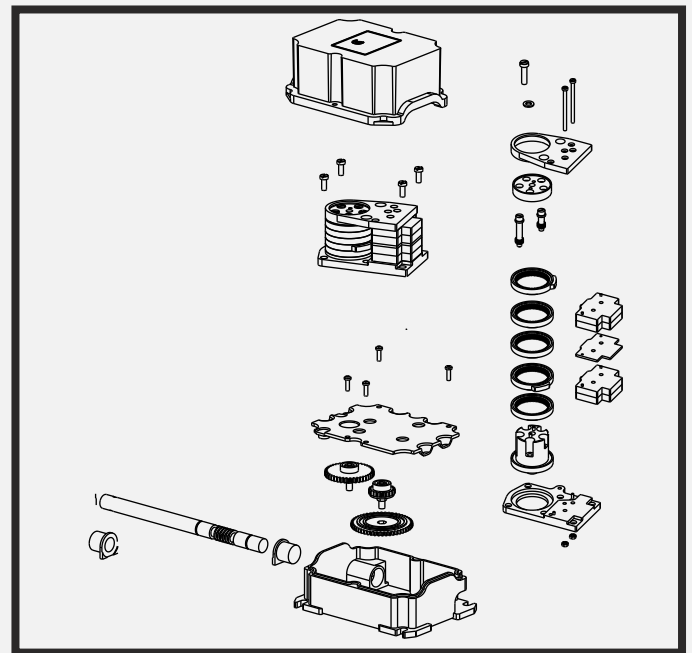
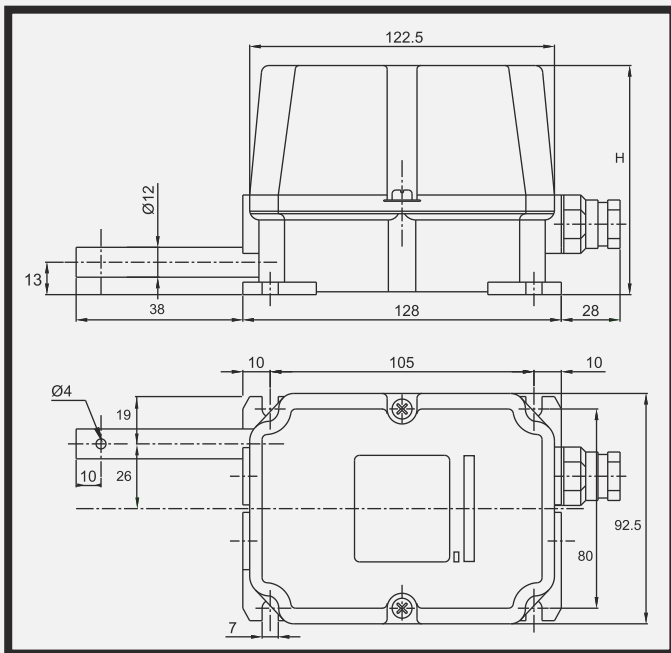

Speed-O-Controls Pvt. Ltd.

H. O. Unit - I : C-15/16, Nand Jyot Industrial Estate, Andheri-Kurla Road, Mumbai - 400072 .
 Tel : (022) 42469700-30
 Fax : (022) 42469797
 E-mail : sales@socgroup.in

Unit - II: Plot No. 4912, G. I. D. C., Phase IV, Vatva, Ahmedabad - 382445
 Tel.: (079) 40083201/2/3/4,
 Fax : (079) 25841056,
 E-mail : sales.amd@socgroup.in

Visit us at :
www.speedocontrols.com
www.socremote.com