

# UNIVERSAL RECTIFIER CONTROL PANEL FOR DC BRAKES



## INTRODUCTION

**BRAKE RECTIFIER UNIT** is used to operate D.C.E.M Brakes shunt type for equipment having A.C main supply. Rectifier unit is suitable to Operate different combination (Individual / Simultaneous) brakes.

Ranging from Ø100 - Ø700

The Standard Panels:

**SINGLE BRAKE**-Individual operation

**TWO BRAKES**- Simultaneous operation.

## SALIENT FEATURES

- ◆ Universal Rectifier for D.C.E.M Brake.
- ◆ Range Ø100 - Ø700 DC Brake.
- ◆ Protection -**MCB & FUSE** Indicator.
- ◆ **IGBT** Controlled DC output Voltage.
- ◆ Compact design.
- ◆ Easy to install & No Settings required.
- ◆ User Friendly.



## TECHNICAL SPECIFICATION

<b>ENCLOSURE</b>	ABS Plastic / Sheet steel	
<b>INGRESS PROTECTION</b>	IP-55	
<b>PAINT</b>	Powered Coated IS-5 Siemens Grey	
<b>INPUT VOLTAGE</b>	380-440 VAC	
<b>OUTPUT VOLTAGE</b>	<b>INRUSH VOLTAGE</b>	300-350 VDC
	<b>HOLDING VOLTAGE</b>	110-120 VDC
<b>CURRENT</b>	50 A	
<b>DUTY</b>	Intermittent / Continuous	
<b>OPERATION</b>	720/hr.	
<b>AMBIENT TEMPERATURE</b>	60°C	
<b>DIMENSION</b>	(320 x 200 x 115) mm	
<b>WEIGHT</b>	1.80 kg	

## CIRCUIT DIAGRAM FOR RECTIFIER DCEM BRAKE

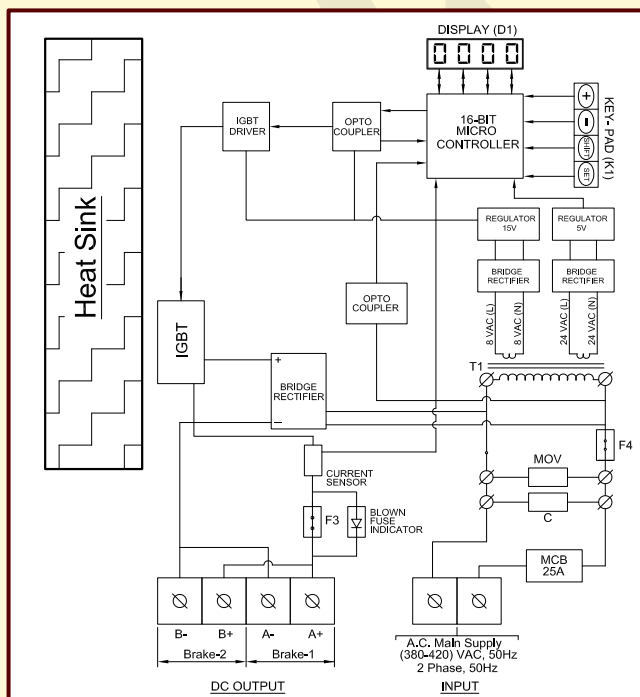

## LAYOUT FOR RECTIFIER CIRCUIT

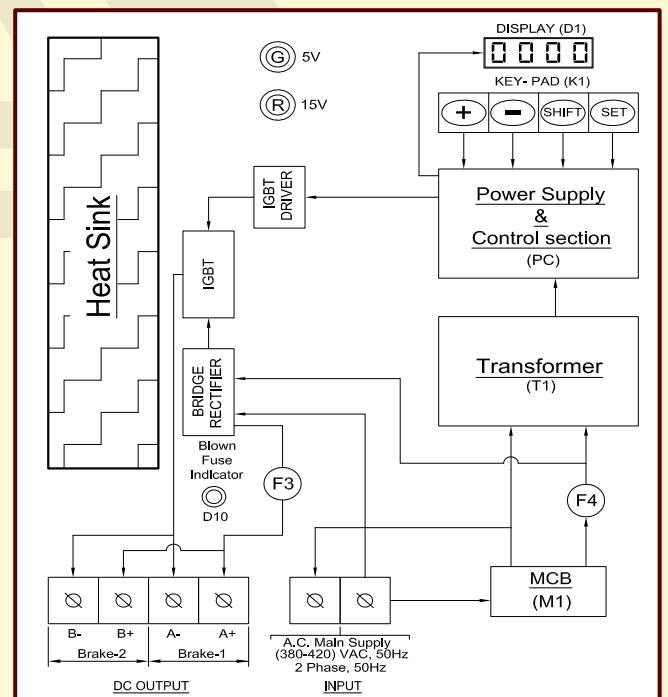

H. O. Unit - I : C-15/16, Nand Jyot Industrial Estate, Andheri-Kurla Road, Mumbai - 400072,  
Tel : (022) 42469700/730  
E-mail : sales@socgroup.in

Unit - II: Plot No. 4912, G. I. D. C., Phase IV, Vatva, Ahmedabad - 382445  
Tel: (079) 68169700/702/712  
E-mail : enquiry2@socgroup.in

Visit us at :  
www.speedocontrols.com  
www.socremote.com  
www.socjoystick.com

**SPEED-O-CONTROLS PVT. LTD.**  
**CRANE CONTROL GEAR**