



RECTIFIER UNIT FOR DC BRAKES

INTRODUCTION

BRAKE RECTIFIER UNIT is used to operate D.C.E.M Brakes shunt type for equipment having A.C main supply. Rectifier unit is suitable to Operate different combination (Individual / Simultaneous) brakes. Ranging from Ø100 - Ø700

The Standard Panels:

SINGLE BRAKE-Individual operation

TWO BRAKES- Simultaneous operation.

SALIENT FEATURES

- ◆ Rectifier for D.C.E.M Brake.
- ◆ Range Ø100 - Ø700 DC Brake.
- ◆ Protection -**MCB & FUSE**.
- ◆ **DIODE BRIDGE** Controlled DC output Voltage.
- ◆ Easy to install & No Settings required.

CIRCUIT DIAGRAM FOR RECTIFIER DCEM BRAKE

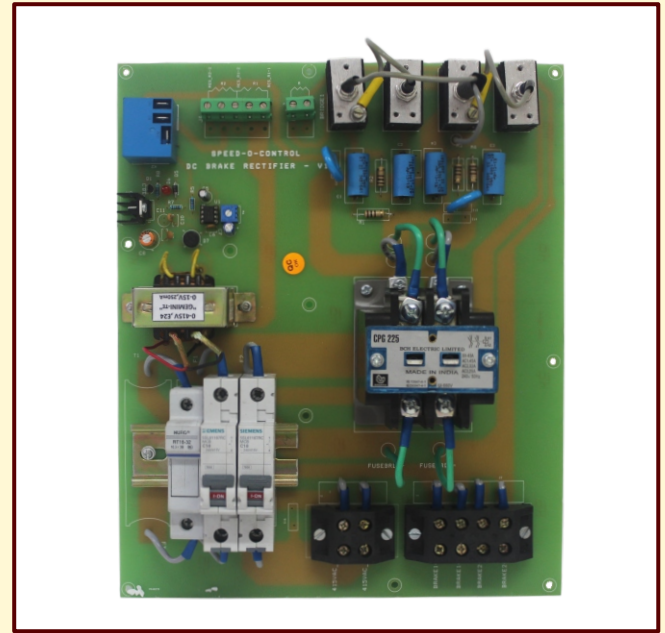
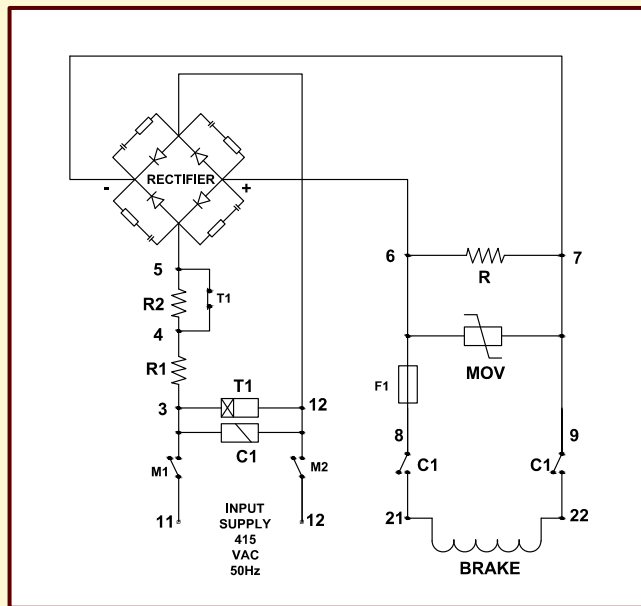

G.A. DRAWING

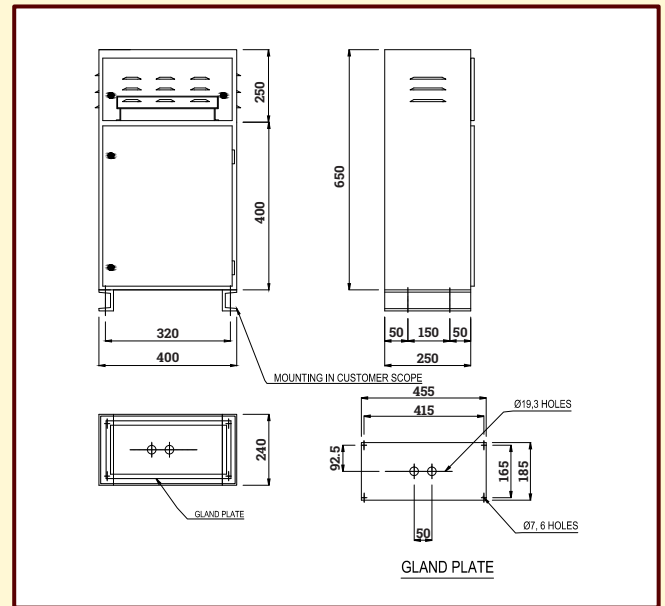

RESISTOR DETAILS R1, R2 & R

Sr. No	Brake Dia	Primary Voltage (V DC)	Holding Voltage (V DC)	R1 (150W)	R2 (150W)	R 150W
1	100	300	110	70 Ω	465 Ω	5K Ω
2	150	300	110	81 Ω	465 Ω	5K Ω
3	160	300	110	81 Ω	465 Ω	5K Ω
4	200	300	110	81 Ω	465 Ω	5K Ω
5	250	300	110	60 Ω	326 Ω	2.2K Ω
6	300	300	110	60 Ω	326 Ω	2.2K Ω
7	400	300	50	6.5 Ω	117 Ω	1.2K Ω
8	500	300	50	6.5 Ω	117 Ω	1.2K Ω

TECHNICAL SPECIFICATION

ENCLOSURE		Sheet steel powder coted
INGRESS PROTECTION		IP-55
PAINT		Powered Coated IS-5 Siemens Grey
INPUT VOLTAGE		400/440 VAC
OUTPUT VOLTAGE	INRUSH VOLTAGE	380 VDC
	HOLDING VOLTAGE	110 VDC
CURRENT		12/30 A
DUTY		Intermittent/Continuous
OPERATION		720/HR.
AMBIENT TEMPERATURE		55°C
DIMENSION		400(W) x 250(D) x 650(H) mm
WEIGHT		12 kg

H. O. Unit - I: C-15/16, Nand Jyot Industrial Estate, Andheri-Kurla Road, Mumbai - 400072,
Tel.: (022) 42469700/730
E-mail: sales@socgroup.in

Unit - II: Plot No. 4912, G. I. D. C., Phase IV, Vatva, Ahmedabad - 382445
Tel.: (079) 68169700/702/712
E-mail: enquiry2@socgroup.in

Visit us at :
www.speedocontrols.com
www.socremote.com
www.socjoystick.com

SPEED-O-CONTROLS PVT. LTD.
CRANE CONTROL GEAR