

Eldro 301/6 & 301/12

Performance Features

- Compact, light weight & elegant design
- Reliable & maintenance free operation.
- Smooth jerk free perfectly linear motion.
- Low noise & does not emit electrical disturbances.
- IP-55, IP-65 degree of protection
- Suitable for out-door installation
- Low power input
- Upto 720 operations per hour.
- Easy mounting and dismounting
- Bi-directional operation.
- Immune from external over-loading
- Immune from supply voltage variations.
- Class F insulation scheme
- Windings for any voltages upto 600VAC 3Ø

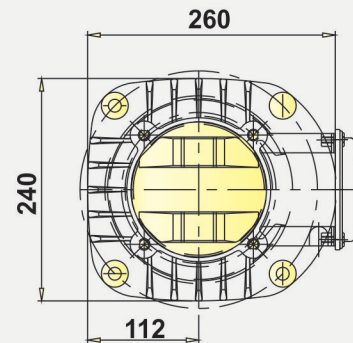
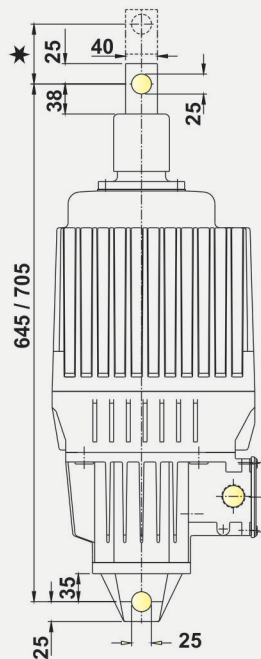
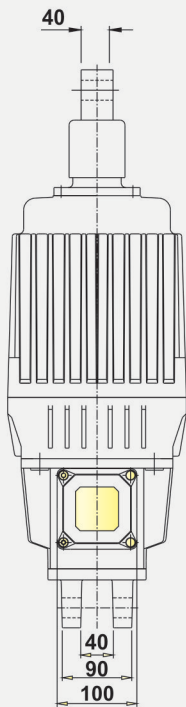

Thruster Model	Item Code	Lifting Force		Stroke (*)	Supply Volts At 50Hz	Input Watts	Oil Capacity	Wt.
		(kg)	(N)					
ELD 301/6	100500016001	301	3010	60	415	550	9.4	44
ELD 301/12	100500016002	301	3010	120	415	550	9.4	44

Supply Voltage 380/480/550/690V available on request.



Speed-O-Controls Pvt. Ltd.

H. O. Unit - I : C-15/16, Nand Jyot Industrial Estate,
Andheri-Kurla Road, Mumbai - 400072 ,
Tel : (022) 42469700-30, 28518512-3-4,
Fax : (022) 42469797/ 28518516,
E-mail : sales@socgroup.in

Unit - II: Plot No. 4912, G. I. D. C., Phase IV,
Vatva, Ahmedabad - 382445
Tel.: (079) 40083201/2/3/4,
Fax : (079) 25841056,
E-mail : sales.amd@socgroup.in

Visit us at :
www.speedocontrols.com
www.socremote.com