



# Master Controller(IP-54)

## Introduction

**Master Controller** is housed in enclosure and provided with an easily removable cover with ample area for maintenance. The cam shaft is mounted on bearing bushes on walls of housing. The cam are made of thermoplastic material and fixed on square spindle switch which is moved by a handle. The cams are cut to correspond to the switching program Aluminum die cast powder coated Suitable for Hoist-Grab, Mill duty, E.O.T. Cranes and Rolling mill drives.



## Technical Data :

Body Material	Aluminum Die Cast
Protection Degree	IP-54(IS/IEC-60529(2001))
Mounting Position	Horizontal
Contact Material	Silver Cadmium
Rated Voltage	500 V.A.C.
Thermal Test Current	40Amps
Cable Entries	2 x 20, 2 x 26 Standard Conduit
Input Speed	1200 RPM Maximum
Contacts	Single Break
No. Of Contacts	24 Maximum
No Of Steps	6-0-6 Maximum
Optional	Spring return/deadman's handle arrangement

## Aluminium Die Cast

Dimension Details						
Type	A	B	C	No.Of Contacts	No. Of Cable Entries	
					Dia 20	Dia 25
Small	170	220	150	8	1	1
Medium	267	317	245	16	2	2
Big	370	420	140	24	2	2

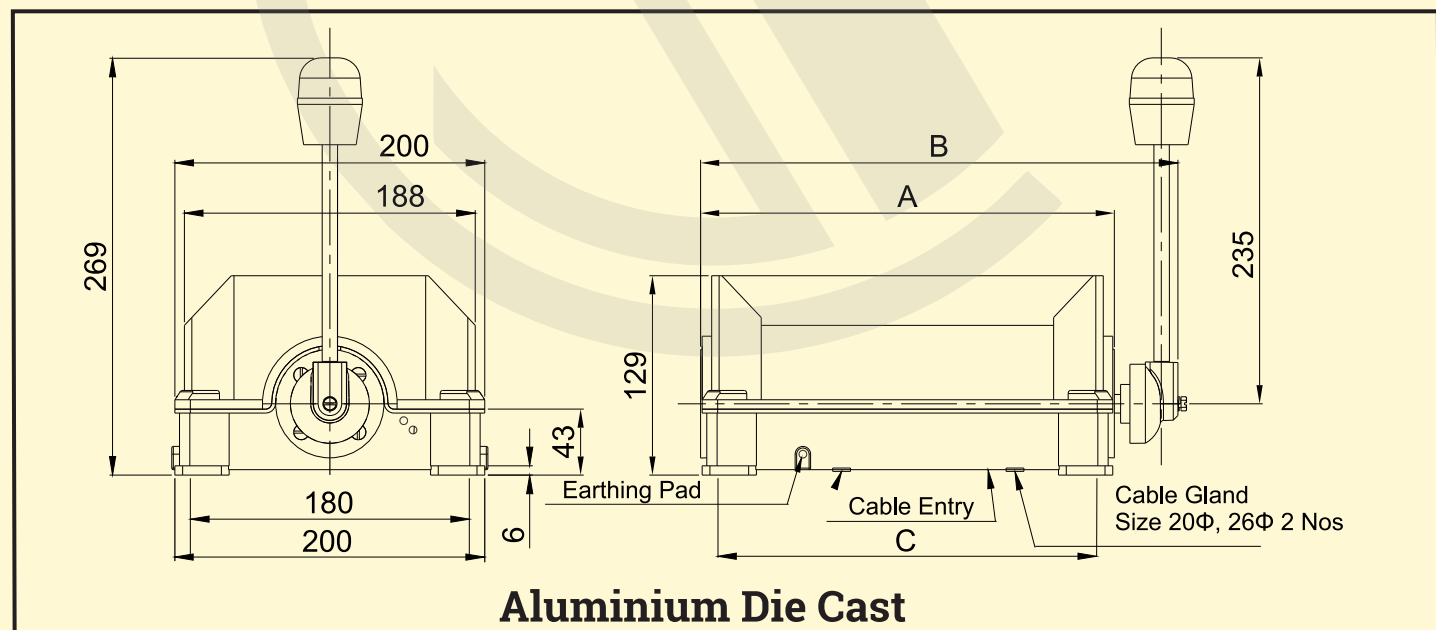

## Aluminium Die Cast

H. O. Unit - I : C-15/16, Nand Jyot Industrial Estate, Andheri-Kurla Road, Mumbai - 400072 ,  
Tel : (022) 42469700/730  
E-mail : sales@socgroup.in

Unit - II: Plot No. 4912, G. I. D. C., Phase IV, Vatva, Ahmedabad - 382445  
Tel.: (079) 68169700/702/712  
E-mail : enquiry2@socgroup.in

Visit us at :  
www.speedocontrols.com  
www.socremote.com  
www.socjoystick.com

**SPEED-O-CONTROLS PVT. LTD.**  
**CRANE CONTROL GEAR**