

# MDT 250-18 ( MILL DUTY THRUSTER BRAKES )



## INTRODUCTION

Thruster Brake is a device to retard the speed of moving machinery and to stop it accurately to the desired position. The breaking force is applied to the brake shoes by a pre-stressed compression spring. The shoes press on the rotating brake drum retarding its speed, and finally stopping it.

## TECHNICAL DATA

ITEM	BRAKE	THRUSTER
MODEL	MDT - 250-18	ST-520
DRUM DIA	250 mm	.....
BRAKE SHOE	Asbestos free/BA	.....
BRAKING TORQUE	35 Kg-m	.....
THRUST	.....	18 Kg
STROKE	.....	50 mm
OIL + CAPACITY	.....	Transformer Oil 2 Litrs
RATED VOLTAGE	.....	415V±10%,3PhAC,50Hz
CURRENT AT 415 V AC	.....	0.4 Amps
POWER	.....	90 Watt
INSULATION	.....	F Class
INGRESS PROTECTION MOTOR ONLY	.....	IP-54 IS/IEC 60529(2001)
SURFACE TEMPERATURE	.....	+50°C
WEIGHT	14 kg	6 kg
POWDER COATING	Colour RAL 7021	.....
<b>OPTION</b>		
LAF	Asbestos Free Liner	.....
LWI	Lining Wear Indicator	.....
OL	Open Brake Limit Switch	.....
MS	Manual Opening & Locking System	.....



## SELECTION OF BRAKE SIZE

Electo-hydraulic thruster is a device which develops linear thrust (or force) required to operate the required mechanism. The input to the device is three phase supply.

The brake torque must be = > than motor full load as referred with drum. Formula as below:

$$T = \text{Torque in Kgm} = \frac{716 \times \text{Hp}}{\text{rpm}}$$

$$T = \text{Torque in Nm} = \frac{9552 \times \text{Kw}}{\text{rpm}}$$

Where Hp/Kw = motor output & rpm = Rev/minute

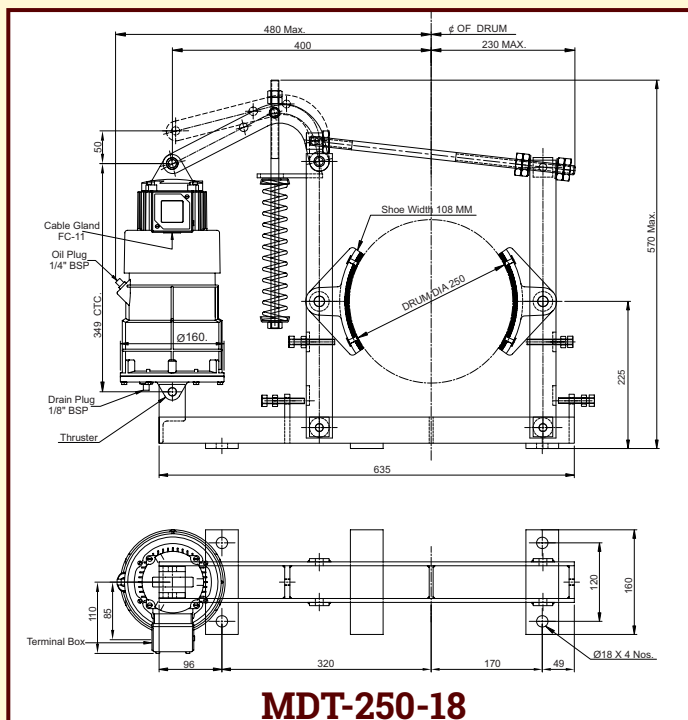

**MDT-250-18**

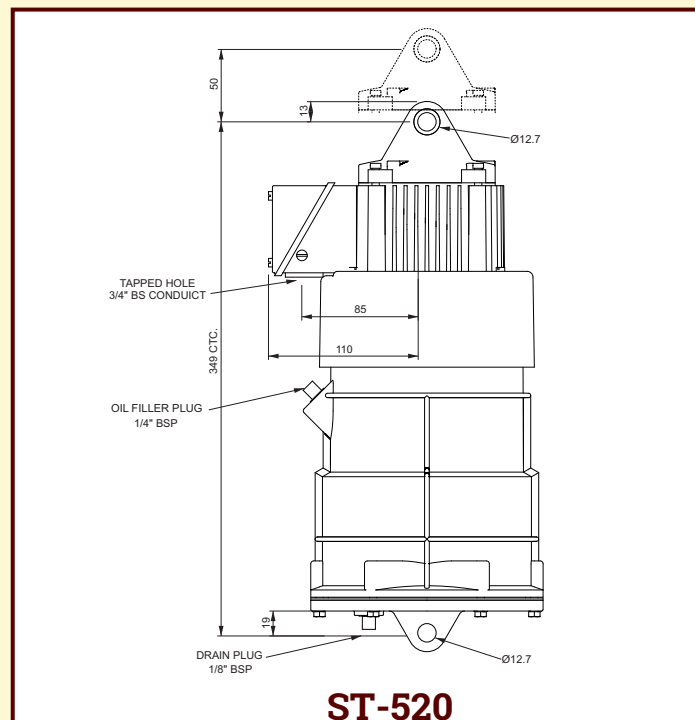

**ST-520**

H. O. Unit - I : C-15/16, Nand Jyot Industrial Estate, Andheri-Kurla Road, Mumbai - 400072,  
Tel : (022) 42469700/730  
E-mail : sales@socgroup.in

Unit - II : Plot No. 4912, G. I. D. C., Phase IV, Vatva, Ahmedabad - 382445  
Tel. : (079) 68169700/702/712  
E-mail : enquiry2@socgroup.in

Visit us at :  
[www.speedocontrols.com](http://www.speedocontrols.com)  
[www.socremote.com](http://www.socremote.com)  
[www.socjoystick.com](http://www.socjoystick.com)

**SPEED-O-CONTROLS PVT. LTD.**  
**CRANE CONTROL GEAR**

