

# ELECTRO-HYDRAULIC THRUSTER (ST)-13300



## INTRODUCTION

An Electro-hydraulic thruster is a device that develops linear thrust (or force) required to operate the required mechanism. The input to the device is a three-phase supply. The thrusters are widely used to actuate. Thruster shoe Brakes, commonly used in material handling machines. Thrusters in various models develop 15 kg to 295 kg. In stroke lengths of 51 mm, 76 mm & 127 mm.

Thrusters should be mounted with in  $\pm 10^\circ$  from vertical. Working fluid Thrusters should be mounted with in  $\pm 10^\circ$  from vertical. Working fluid - Transformer oil to BS 148.

## TECHNICAL DATA

THRUSTER MODEL	ST - 13300
LIFTING FORCE	295 Kg
STROKE	127 mm
CURRENT	1.25 Amps
POWER	420 Watt
OIL CAPACITY	9 Liters Transformer Oil
WEIGHT	55 Kg
VOLTAGE A.C.	415V 3 $\phi$ ,AC
INGRESS PROTECTION	IP-55 (IS/IEC 600529:2001)
AMBIENT TEMPERATURE	50°C Max
NO.OF START	720/hr

★ 380V, 460V, 550V on Enquiry



**ELECTRO-HYDRAULIC THRUSTER  
MODEL ST 13300**

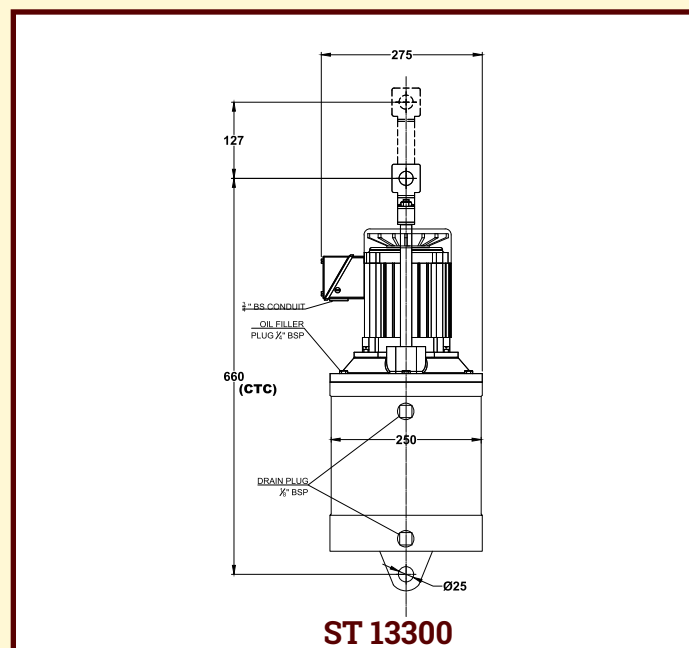
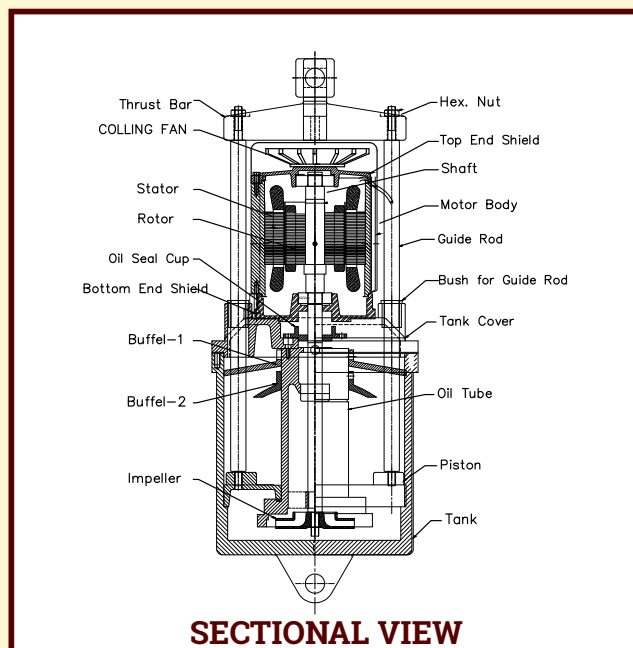

H. O. Unit - I : C-15/16, Nand Jyot Industrial Estate, Andheri-Kurla Road, Mumbai - 400072,  
Tel : (022) 42469700/730  
E-mail : sales@socgroup.in

Unit - II: Plot No. 4912, G. I. D. C., Phase IV, Vatva, Ahmedabad - 382445  
Tel.: (079) 68169700/702/712  
E-mail : enquiry2@socgroup.in

Visit us at :  
www.speedocontrols.com  
www.socremote.com  
www.socjoystick.com

**SPEED-O-CONTROLS  
PVT. LTD.**

**CRANE CONTROL GEAR**