

## INTRODUCTION

SOC operated brakes type 'E' are designed for long life, easy installation and minimum maintenance . They are electrically released and spring applied providing 'Fail Safe' operation. The retarding torque developed is directly proportional to the spring pressure.

## CONSTRUCTIONAL FEATURES

Special constructional features such as those listed below account for exceptionally long mechanical life of the brakes.

### NEOPRENE SHOCK ABSORBER -

Prevents link pin breakage and increases the life of the solenoid.

### HARDENED STEEL LEVER AND SPRING GLAND -

The hardened steel construction of the lever and spring gland reduces wear at the pins and all other points of contact.

### CAST IRON WHEEL -

The physical properties of the minimize the tendency of the wheel to deposit metal particles in the lining which could result in serious scoring of the wheel.

### SPRING PINS -

The tight gripping spring pins insure against the loss of pins due to shock.

### INEXPENSIVE LINING REPLACEMENT -

Linings attached to shoes by removable flat head groove-pins.

### FEWER JOINTS -

The shoe is actually a part of shoe lever and not separate from it . This makes for fewer mechanical joints and keeps wear points at a minimum.

### SOLENOID -

The solenoid coil can be removed without disturbing the brake adjustment. Solenoid loading is designed to reduce wear.

## BRAKE SELECTION

The method most generally used to determine the required braking torque is to calculate the full load motor torque by means of the following formula:

$$T = \frac{9552 \times kW}{n}$$

**T** = Full load motor torque in Newton Metre (Nm)

**kW** = Motor output in Kilowatts

**n** = Rated speed of the motor shaft on which brake wheel is mounted in revolution per minute(r.p.m)

The torque rating of brake selected should be at least equal to the full load motor torque for the duty considered.

BRAKE TYPE	DRUM DIA		TORQUE MAX (KGM)	
	INCH	MM	INTERMITTENT	CONTINUOUS
EMD - 4	04	100	2.25	1.3
EMD - 5.5	5.5	139.7	4.8	3.4
EMD - 7	07	177.8	10.2	6.8
EMD - 10	10	250	-	14.7

## TECHNICAL SPECIFICATION

MODEL	E-4	E-5.5	E-7
ITEM CODE	900710010001	900710020001	900710030001
DRUM DIA (MM)	4" (101.6 mm)	5.5" (139.7mm)	7" (177.8mm)
BREAKING TORQUE (INTERMITTENT)	-	4.8 kgm	10.2 kgm
BREAKING TORQUE (CONTINUOUS)	1.36 kgm	3.4 kgm	6.8 kgm
STROKE (MM)	25	31.4	31.4
VOLTAGE IMPUT	415	415	415
HOLDING VOLTAGE	415	415	415
OPERATING TEMPERATURE	Ambient Temp.	Ambient Temp.	Ambient Temp.
COIL	CLASS F Insulation	CLASS F Insulation	CLASS F Insulation
RATING	Intermittent	Intermittent	Intermittent
NO OF OPERATIONS	720 Operations/Hr	720 Operations/Hr	720 Operations/Hr
TOTAL WEIGHT (KG)	5.5kg	11.5kg	15.5kg

## AC SOLENOID BRAKES-E SERIES

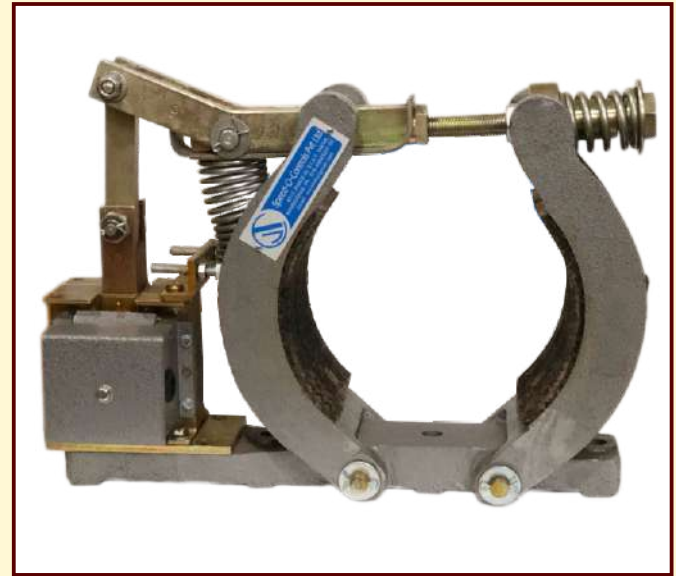

## DIMENSIONS (MM)

BRAKE SIZE	BREAKING TORQUE (KGM)		A	B	C	D	E	F	G	H	J	K	P	Q	R
	INTERMITTENT	CONTINUOUS													
4.0"	-	1.3	102	73	178	67	32	140	78	10	16	73	79	76	79
5.5"	4.8	3.4	140	102	240	89	51	213	105	11	25	124	79	95	79
7.0"	10.2	6.8	178	127	291	111	64	241	127	14	25	152	79	121	79

Note: 10" details also available on request.

## G A DRAWING

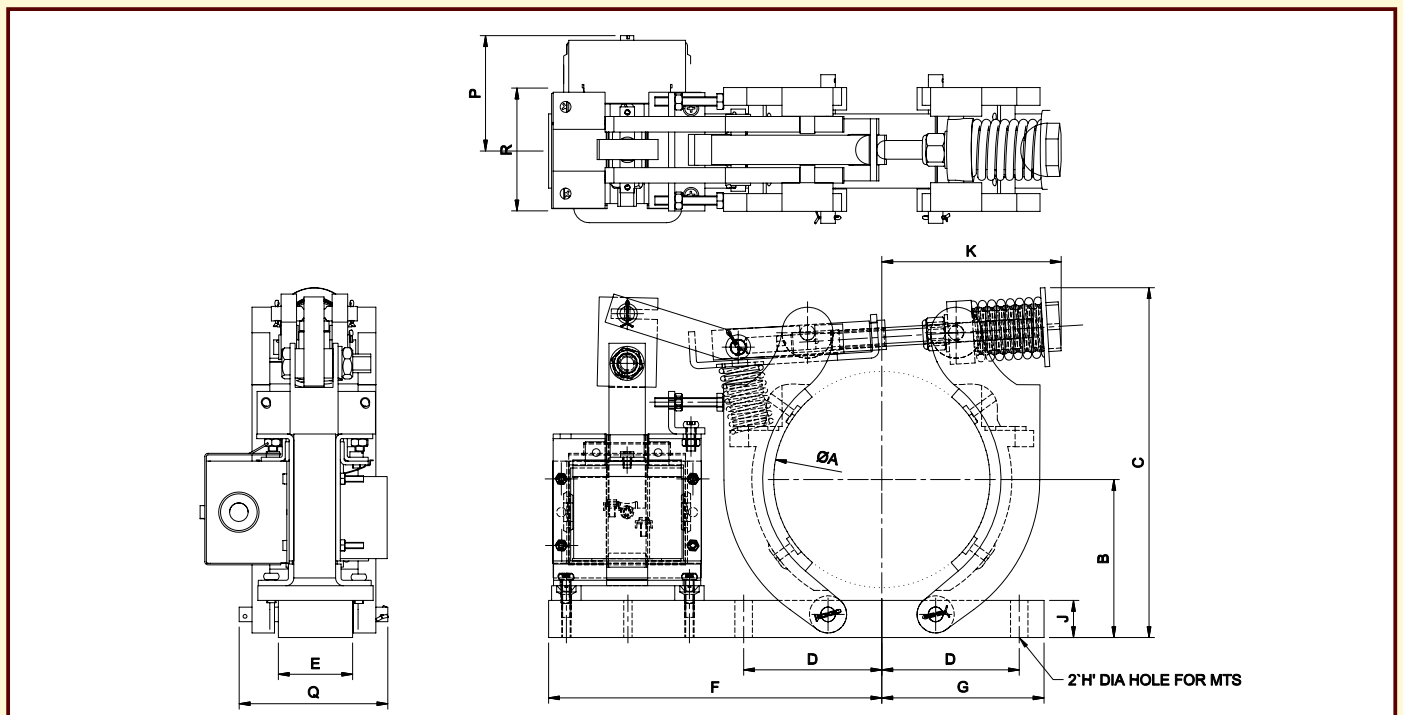

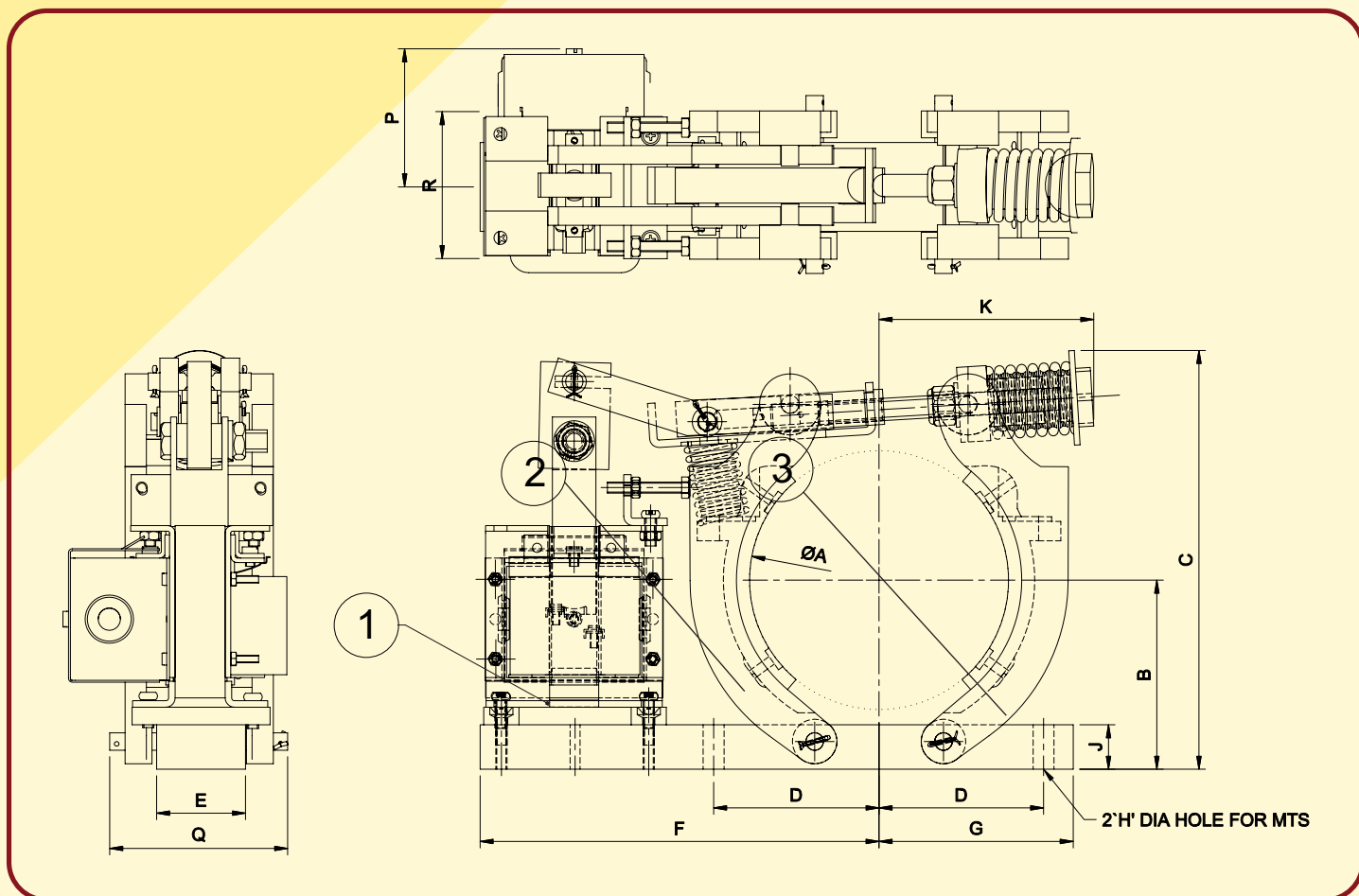

## SPARES FOR ACem SOLENOID BRAKE

<b>1</b> 	<b>2</b> 	<b>3</b> 
BRAKE COIL	BRAKE SHOE ASSEMBLY	BRAKE LINING

MODEL	BRAKE SIZE		
	4.8"	5.5"	7.0"
BRAKE COIL	E4CL	E5CL	E7CL
BRAKE SHOE ASSEMBLY	E4BSWL	E5BSWL	E7BSWL
BRAKE LINING	E4BLWR	E5BLWR	E7BLWR